

## A FAST, LOW POWER CONSUMPTION READOUT SYSTEM FOR A SPACE BASED CALORIMETER

G. BASINI, F. BONGIORNO <sup>1)</sup>, A. MORSELLI, M. OCCHIGROSSI, M. RICCI and P. SPILLANTINI

*Laboratori Nazionali INFN, Frascati, Italy*

<sup>1)</sup> *Dipartimento di Metodi e Modelli Matematici dell'Università "La Sapienza", Roma, Italy*

A. CODINO, C. GRIMANI, M. MENICHELLI, E. RONGONI and I. SALVATORI

*Dipartimento di Fisica dell'Università and INFN, Perugia, Italy*

P. PICOZZA

*Dipartimento di Fisica dell'Università, Tor Vergata, Roma, Italy, and Laboratori Nazionali INFN, Frascati, Italy*

L. DE BORTOLI

*DB2 Electronics, Arese (Mi), Italy*

C. BIANCHI

*AUR. EL. Microsystem, Tradate (Va), Italy*

Received 5 September 1988

The characteristics of a fast and compact readout system of a tracking calorimeter to be installed on a balloon-borne apparatus are described. The specific constraints of the experiment have imposed the search for a good compromise between fast signal collection, gain stability, compactness and low power consumption. The solution adopted exploits hybrid circuit technology and a modular multistage preamplifier configuration.

### 1. Introduction

In this article we describe the readout system of a tracking calorimeter to be installed in a balloon-borne apparatus consisting of a superconducting magnet, time-of-flight counters and track chambers. This readout takes advantage of the hybrid circuit technology and has been specifically designed for the experiment MASS (Matter–Antimatter Space Spectrometer), which aims at the measurement of the primary antiproton flux in high atmosphere ( $\sim 40$  km) in the energy range 0.3–1.0 GeV. The interest in such a measurement comes from the results of previous similar experiments [1] which showed an antiproton flux much higher than that calculated by current models.

### 2. Design considerations

The tracking calorimeter is a box  $52 \times 52 \times 40$  cm<sup>3</sup>, made of 50 planes of brass streamer tubes (64 tubes per plane) interleaved with 50 planes of pickup strips (64 strips per plane) for a total of 6400 readout channels.

The internal size of a single tube is  $6.5 \times 5.0$  mm<sup>2</sup>. A gold plated tungsten wire (50  $\mu$ m in diameter) is stretched at the center of each tube.

In order to satisfy the peculiar conditions of a balloon-borne experiment, the following general requirements have been taken into account in the design of the readout system:

- 1) The entire readout system needs to be compact.
- 2) Minimum power consumption.
- 3) The electronics should be located as close as possible to wires and strips in order to avoid signal degradation.
- 4) The signal from wires and strips, being fast (width  $\approx 20$  ns, risetime  $\approx$  few ns), needs a high speed amplifier.
- 5) Fast and low power consuming discrimination and conversion into TTL logic.

### 3. Description of the circuit

The front-end electronics of a half plane (wires and strips) of the calorimeter is controlled by a 32-channel

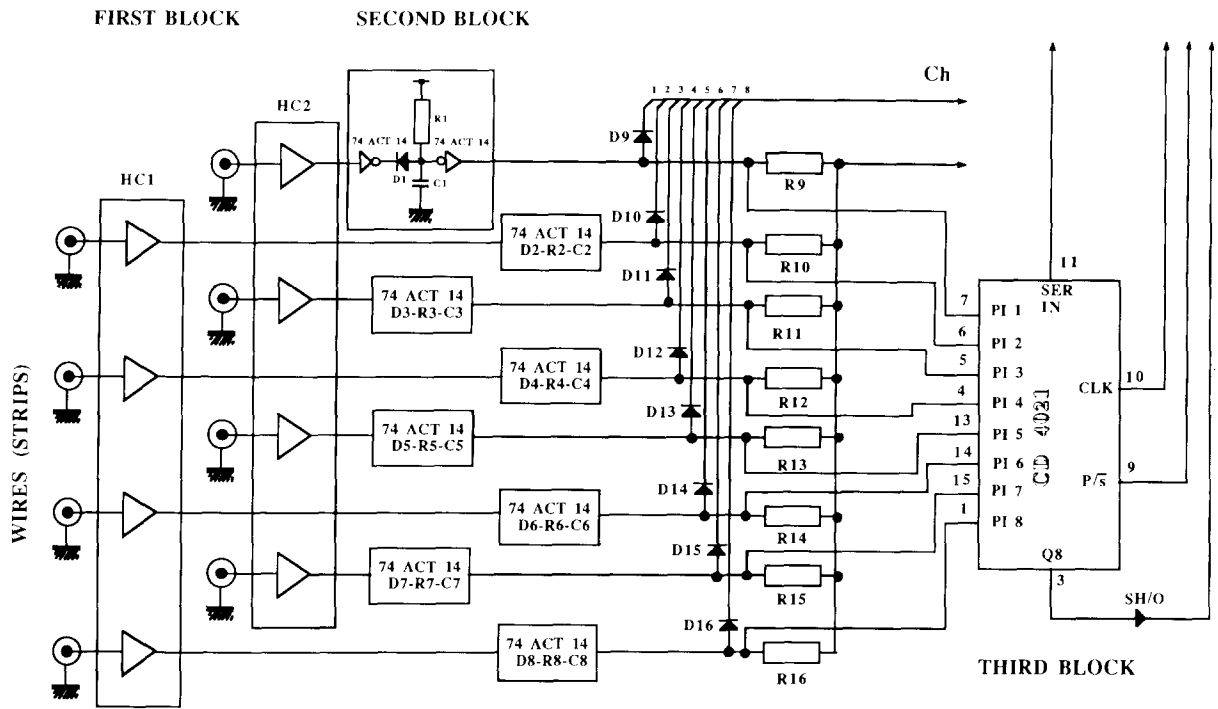

Fig. 1. The three main functional blocks of the front-end electronics.

card whose amplifier section is composed of three main functional blocks, as shown in fig. 1.

The requirement of compactness is satisfied by allocating the electronics inside the calorimeter box itself. This has been possible by using hybrid circuit technology and a specific engineering solution which allows to fix high-density printed boards on both sides of each streamer tube plane.

The first functional block, which is also the closest to wires and strips, is a typical charge amplifier. Due to the requirement of very short rise time, a multistage preamplifier configuration has been employed. Another important design requirement is a local feedback for each stage to ensure stability in the selected gain.

The preamplifier configuration which has been chosen is a simplified version of the Goyot-Samueli-Sarasin amplifier [2] which, for wire signals as shown in fig. 2, is made of two stages, while for strip signals (fig. 3), it is made of three stages, to take into account that the induced signal collected by the strips is about 3 times lower than the signal collected on the wires. The basic section is a common base transistor (T1) stage driving a common emitter stage with a feedback resistor. The relevant parameters for this preamplifier configuration have been investigated by the simulation program SPICE [3].

The major problem was to reach the best compromise between gain, rise time and power consumption.

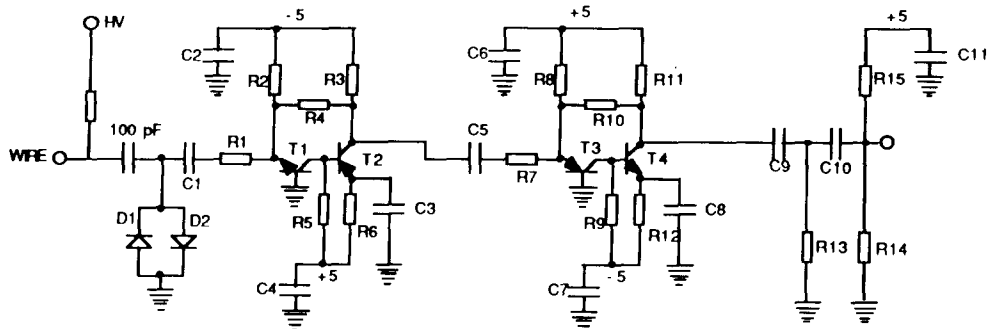
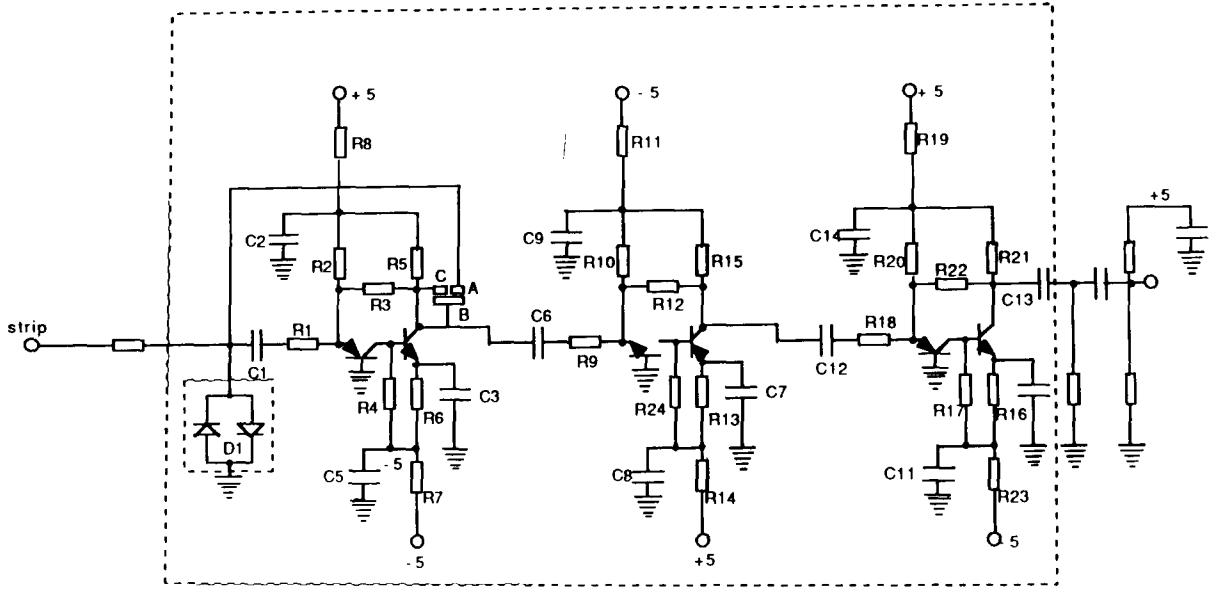

Fig. 2. Circuit diagram of the wire preamplifier showing the two stage amplifiers (T1, T2, T3, T4).



AUR EL MICROSYSTEM S.r.l.  
Via Monte Grappa, 73  
Tradate (VARESE)

Fig. 3. Circuit diagram of the strip preamplifier, where one more stage is present with respect to fig. 2.

The solution adopted was a three stage preamplifier for strips and a two stage preamplifier for wires. The power dissipation has been reduced down to 15 mW per channel with a gain of ~ 500 for strips and ~ 100 for wires with a stability in the gain which is better than 0.2%/°C. The measured rise time is ≤ 5 ns. The most relevant parameters of the amplifier circuit are summarized in table 1.

Table 1  
Specification of the amplifier/discriminator/monostable

Input impedance	50 Ω (± 30%)
Minimum detectable input width	10 ns
Noise	< 1 μA rms
Output levels	clamped at +5 V during output
Outputs	one per channel with active drive
Output sink current	> 2 mA
Output duration	proportional to timing capacitor, 500 ns to 10 μs range
Output transition time	negative edge < 5 ns positive edge < 5 ns
Output rise time	5 ns(10%-90%)
Output fall time	5 ns(10%-90%)
Recovery time	< 50% of T (T = output duration)
Supply current	+5 V < 1.5 mA; -5 V < 1.5 mA
Total power consumption	15 mW per channel
Package	4 or 2 channels hybrid package
Dimensions	65 × 26 mm

In order to reduce the spread in the characteristics of the 6400 preamplifier circuits, the gain in each amplifier stage is defined by a resistor and is independent of the transistor parameters.

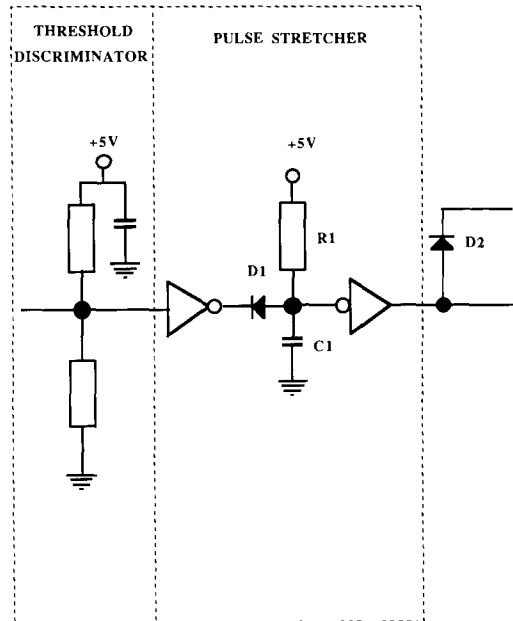

Fig. 4. Threshold discriminator and pulse stretcher showing the configuration of CMOS Schmitt trigger inverters.

The second functional block, shown in fig. 4, is a fixed threshold pulse detector and pulse stretcher. It is based on Schmitt trigger inverters in CMOS technology of the last generation. Such a choice provides both low power dissipation and high speed. The output pulse duration, defined by the resistor, the capacitor and the voltage supply, has been fixed from 1 to 2  $\mu$ s.

The third functional block (CD 4021) performs all the functions necessary to generate the same status flags to the remote digital electronics and to allow a temporary storage of all wire and strip statuses inside the calorimeter. Temporary storage is performed by CMOS shift registers which are loaded simultaneously by the external storage command.

For each wire group (32 channels) an analog output signal, proportional to the number of fired wires, is available. This function is accomplished by adding an operational amplifier to the output discriminators. Such an analog signal can also be used in the trigger definition.

#### 4. Data acquisition

For readout and trigger purposes the calorimeter has been subdivided into eight sectors, the first two sectors corresponding to wires in the  $x$  direction, the third and fourth to wires in the  $y$  direction and the same applies for the strips. Each sector is in turn divided into four

subsectors so that  $\frac{1}{32}$  of the calorimeter can operate and can be controlled independently.

The digital outputs stored inside the calorimeter are controlled by four CAEN STAS (Streamer Tube Acquisition System) modules which perform the readout of the calorimeter in serial mode by converting every (or a group of) significant channel into a 16-bit word and storing this word into a  $512 \times 16$  bits FIFO; this conversion is made at a maximum rate of 1.25 Mb/s per channel; the data are then sent to a standard CAMAC interface.

The balloon-flight configuration uses a PDP 11/73 for control and data compression. A first event filter is accomplished on board by a Microvax II which also sends the data to the ground by means of a telemetric link at the rate of 156 kbits/s.

#### References

- [1] R.L. Golden et al., *Phys. Rev. Lett.* 43 (1979) 1196; A. Buffington et al., *Astrophys. J.* 248 (1981) 1179; E.A. Bogolomov et al., *Proc. 16th Int. Cosmic Ray Conf.*, vol. 1 (Kyoto, 1979) p. 330.
- [2] M. Goyot et al., *Nucl. Instr. and Meth.* 46 (1967) 149.
- [3] SPICE is a program developed at the University of California, Berkeley, in 1970, by L.W. Nagel (SPICE 2. A computer program to simulate semiconductor circuit; Memorandum N.ERLM520, 1970) and E. Cohen (Program reference for SPICE 2; Memorandum N.ERLM592, 1970).