

The PAMELA Transition Radiation Detector

F.S. Cafagna¹ for the PAMELA Collaboration

¹University and INFN, Bari, Italy

Abstract

A Transition Radiation Detector (TRD) has been developed for the PAMELA instrument. PAMELA is a satellite born magnetic spectrometer; its primary scientific objective is the study of antiparticles in cosmic rays. The TRD detector was developed to provide particle identification, in addition to calorimetric measurements. This detector is composed of 9 active layers made of proportional straw tubes, piled up with interleaved carbon fibers radiator layers. Detector description and test beam performances will be presented.

1 Introduction

Investigation of antiparticle spectra for energies larger than 10 GeV is of great importance in understanding the origin and propagation of cosmic rays. Past investigations, with balloon borne detectors, of both positron and antiproton spectra showed larger fluxes than expected on the basis of a simple leaky box model. Among the limitations to the measurements were the correct calculation of the antiparticle produced in the atmosphere overburden and the exposure factor. PAMELA detector has been designed to overcome these problems, being a satellite borne detector studied to have a three year measurements cycle in orbit.

In positively identifying positions a large background of proton has to be subtracted. rejection factor greater than 10^5 are required. Besides the investigation of high energies requires a spectrometer with large maximum detectable rigidity (MDR). For this reasons, along with a silicon tracker spectrometer reaching a spartial resolution better than $7 \mu\text{m}$, PAMELA will be equipped with a transition radiation detector (TRD), that together with a silicon-tungsten calorimeter will provide the required hadron rejection.

2 PAMELA Detector

PAMELA instrument will be extensively described elsewhere in this conference (Adriani 1999b). It is composed from the top to the bottom by: a time of flight system (Tof), a transition radiation detector (TRD), a silicon tracking system (Adriani 1999a), a permanent magnet, a silicon-tungsten calorimeter (Bonvicini 1999). In fig.1 a section of the instrument is shown.

3 The TRD

PAMELA TRD will be placed on top of the detectors stack, as shown in fig. 1. It is modular in design. The basic component is a straw of 4mm in diameter and 28cm in length. It is made of $30 \mu\text{m}$ thin Kapton foil. Inside, a $25 \mu\text{m}$ in diameter, tungsten anode wire is stretched to a tension of 70g.

Each straw modules is filled with a mixture of Xe and CO₂ (80%, 20%). With this gas mixture the operating voltage is 1400 between the anode wire and the cathode straw wall. They are designed to work in gas sealed mode.

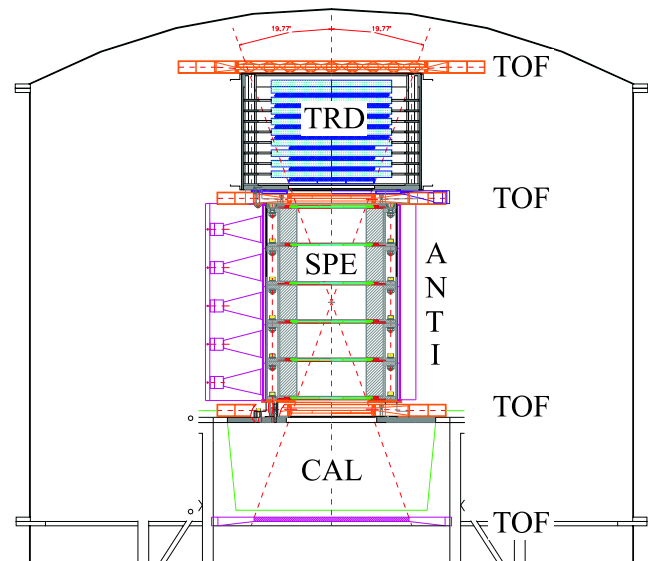

Figure 1: A section of the PAMELA instrument

32 straws are grouped together to form a module. They are arranged in two 16 straw layers placed on top of the other and displaced to maximize the acceptance. An artistic view of this module is shown in 2.

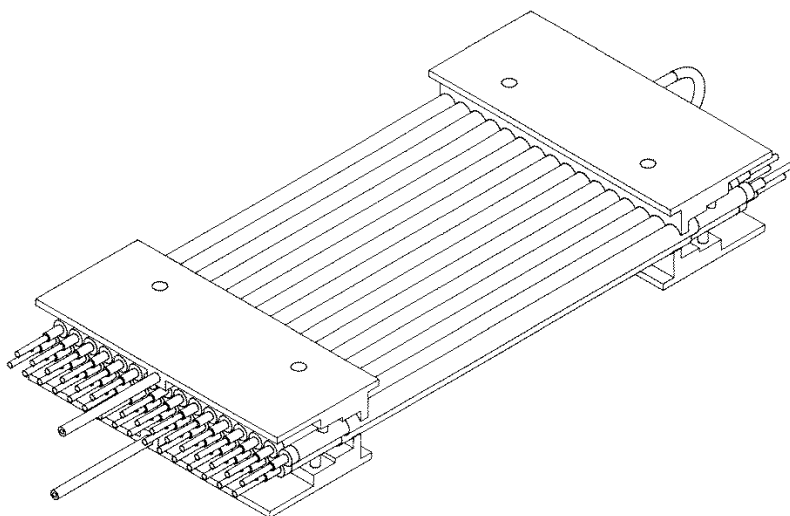

Figure 2: Artistic view of a 32 straws module

These modules are placed sideways, on a special frame, to form a plane. The full TRD is made of 9 of these planes for a total of 32 modules for a total of 1024 straws. A configuration of 5 planes of 4 modules placed on top of 4 planes of 3 modules has been chosen to maximize the acceptance.

The WiZard collaboration already flew a TRD in the TS93 balloon borne detector (Barbarito 1992, Bellotti 1997). From the experience of this design and Monte Carlo simulation a carbon fiber radiator has been chosen for this detector. Carbon fibers are

packed in bags of 60g/l density and placed in the space left in between two planes.

A critical point in the mechanical design is the presence of a gas feeding system and the high voltage distribution in a small volume. To solve this problem the sixteen straw tubes forming half of a 32 straw module, are kept in side by mean of specially manufactured brass plates that act also as manifolds for the gas mixture. Besides “T” shaped pipe are glued on the straw ends and inserted in the brass plate to provide: gas circulation inside the single tube, housing for the electrical connector, ground connection. The high voltage connection is provided by special machined plugs-in soldered to the anode wire and placed, inside a fiber glass insulating pipe, into the “T” shape piece. An exploded view of a straw end and its insertion in the base plate is shown in fig.3.

To ensure mechanical stability and proper gas sealing the two 16 straw layers are glued face to face with liquid epoxy.

4 Prototype Tests

The satellite environment sets stringent constrains in term of mechanical and thermal stability, aging and gas leakages.

For this reasons vibrational tests have been carried out on a TRD module prototypes, showing no modification in the electrical and mechanical characteristics. Besides overpressure tests showed that the straw mechanical characteristics are maintained after 4 atm overpressure.

Prototypes have also been tested for gas leaks finding a rate of $3 \div 4 \times 10^{-3}$ (Torr l)/sec at 1 atm overpressure, for Argon based mixtures.

Gas mixtures and high voltage settings have been investigated using 5.9 KeV photons from Fe55 sources. These tests showed that the 80% Xe 20% CO₂ gas mixture and a voltage of 1400 V, maximize the photon conversion and operate the straw in a moderate gain region.

To evaluate the proper front-end electronic technique to be used, test have been carried out at the SPS facility, at CERN, using a 3GeV pion and electron beam. From these test a charge integrating (ADC technique) instead of a fast discriminating electronics (Cluster Counting technique) has proven to have better perfor-

mances in term of hadron rejection. In fig.4 the hadron contamination versus the electron detection efficiency is reported for both techniques, in case a statistical indicator (Likelihood) or the physical information are used.

At the moment the mass production of the full TRD is ready to start and new test at the CERN facilities are foreseen in the next months that will be presented by the time of the conference.

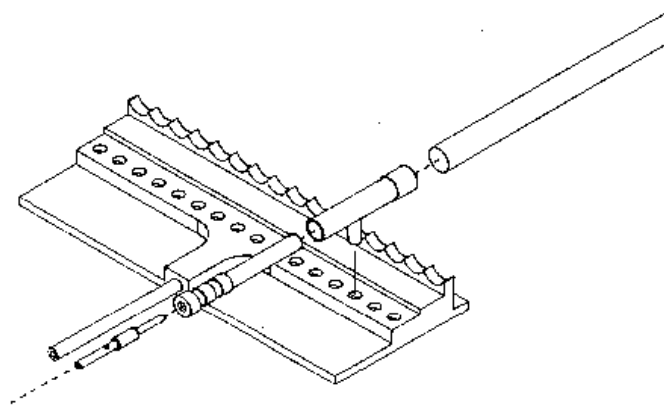

Figure 3: Exploded view of a straw connection to the gas manifold and HV connector.

5 Conclusions

The PAMELA TRD prototypes have been extensively tested and the mass production started. This detector has been designed to work for three years in a satellite environment and to reach rejection factor of the order of 10^{-2} in spite of a reduced height. A test beam campaign of the TRD detector flight model will take place in the next months.

References

- Adriani O., et al. 1999a, Proc. 26th ICRC (Salt Lake City, 1999), OG.4.2.10
- Adriani O., et al. 1999b, Proc. 26th ICRC (Salt Lake City, 1999), OG.4.2.04
- Barbarito E., et al. 1992, Nucl. Instr. Meth. A313, 295

Bellotti R, et al. 1997, Nucl. Phys. B 54B, 375

Bonvicini V., et al. 1999, Proc. 26th ICRC (Salt Lake City, 1999), OG.4.2.33

