

## The ToF System of the PAMELA Experiment: In-orbit Performance

WOLFGANG MENN<sup>1</sup> FOR THE PAMELA COLLABORATION

<sup>1</sup>University of Siegen, Siegen, Germany

menn@pamela.physik.uni-siegen.de

**Abstract:** A time-of-flight scintillator system (ToF) has been developed for the PAMELA satellite-borne cosmic ray experiment, mounted on the Resurs DK1 satellite and launched from the Baikonur cosmodrome on June 15<sup>th</sup> 2006. PAMELA was built to measure charged particles in the cosmic radiation with a particular focus on antiparticles. The ToF scintillator system provides the fast trigger to the experiment, the rejection of albedo particles, and in combination with a magnetic spectrometer the possibility to distinguish electrons from anti-protons up to about  $\sim 1$  GeV and to separate light isotopes at low energies. Ionising energy loss measurements in the scintillator planes allow the absolute charge of traversing particles to be determined. The in-orbit performance of the ToF system is presented.

### The PAMELA satellite experiment

The PAMELA satellite-borne cosmic ray experiment [1] was built to measure charged particles in the cosmic radiation with a particular focus on antiparticles. It was mounted on the Resurs DK1 satellite and launched from the Baikonur cosmodrome on June 15<sup>th</sup> 2006. Details about the science of PAMELA [2] as well as about the flight data and general status [3] will be described in separate papers in this conference. In this paper we will focus on the in-orbit performance of the time-of-flight system.

### The time-of-flight (ToF) system

The ToF system [4], shown in Figure 1, comprises six layers of fast plastic scintillators (Bicron BC-404) arranged in three planes (S1, S2 and S3), with alternate layers placed orthogonal to each other. The distance between S1 and S3 is 77.3 cm. Time-of-flight information for charged particles passing between planes S1 and S3 is combined with track length information derived from the magnetic spectrometer to determine particle velocities and reject albedo particles. Ionisation ( $dE/dx$ ) measurements in the scintillator layers allow the particle charge to be determined up to  $Z < 8$ . Coincidental energy deposits

in combinations of planes provide the main trigger for the experiment. The segmentation of each plane allows redundant studies of the trigger efficiency.

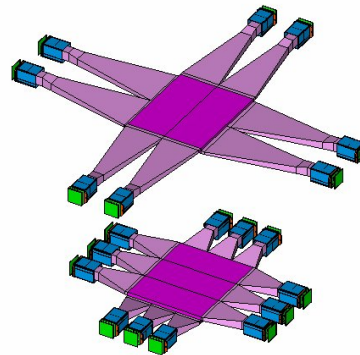
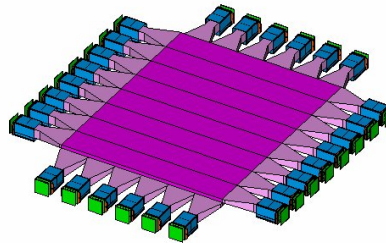

Figure 1: The PAMELA time-of-flight system

The sensitive area of each of the two S1 layers is (33-40.8) cm<sup>2</sup> with the first layer divided into 8 bars and the second layer divided into 6 bars. The total sensitive area of the S2 and S3 planes is (15-18) cm<sup>2</sup> segmented into 2·2 and 3·3 orthogonal bars, respectively, so there are 24 scintillator bars in total. The S1 and S3 layers are 7 mm thick while the S2 layers are 5 mm thick. Both ends of each scintillator bar are glued to a plastic light-guide which is mechanically coupled to a Hamamatsu R5900U photomultiplier (PMT) by means of silicone pads of thickness 3 mm (S1 and S2) and 6 mm (S3). The differences in thickness of the pads were obtained in vibration tests and respect the different vibrational spectra expected during launch. The scintillators and light-guides are wrapped in two layers of 25  $\mu$ m thick Mylar foil. The S3 plane is mounted directly on the base plate of PAMELA, while the other two planes are enclosed in light-proof boxes suspended off the PAMELA structure. A high-voltage divider circuit is mounted directly behind each PMT. The high-voltage and discrimination threshold for each PMT is chosen to optimize the performance of a given ToF bar.

The ToF electronics system converts the 48 PMT pulses into time- and charge-based measurements. In the timing section, a capacitor is linearly charged during the short time interval defined by the passage of a particle through the ToF system. In the charge section, a capacitor is charged with the PMT pulse charge. In both cases, during read out the capacitor is linearly discharged via a time-stretcher into a time-to-digital converter.

The ToF electronics system [5] comprises a nine board electronics system based around the PAMELA-standard FPGAs and DSPs. A separate trigger board processes signals from the 48 PMTs as well as trigger signals from the calorimeter and bottom scintillator.

Rate counters, dead-/live-time counters and the logic to generate calibration pulse sequences for different subsystems are also implemented. Control masks select trigger types and allow noisy or dead PMT channels to be vetoed and the PMT hit pattern to be recorded for each trigger.

### Single Paddle Resolution

One of the ways to determine a representative figure for the timing resolution of the TOF system

is shown for one of the paddles of the top layer in Figure 2. For events that had been identified as protons ( $Z=1$ ), the position of the incident particle along the paddle as determined from the timing of the pulses in the two PMTs (in units of nanoseconds) is shown plotted versus the position as determined by the tracker. Note, that this plot shows the raw timing measurements without any amplitude or position corrections.

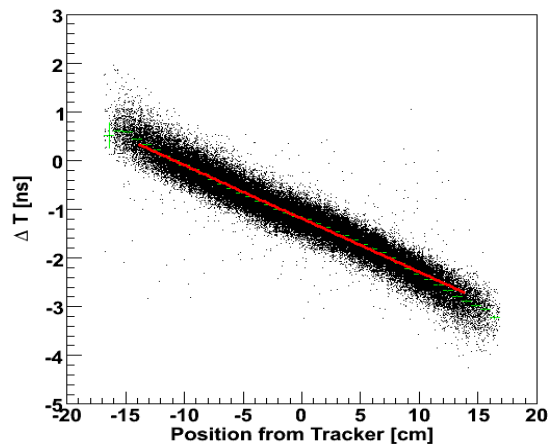

Figure 2: Position of the incident particle from timing vs. position from particle trajectory

A linear fit to the distribution is shown as well, and subtracting it yields the distribution of timing deviations from the tracker-position which is shown in Figure 3:

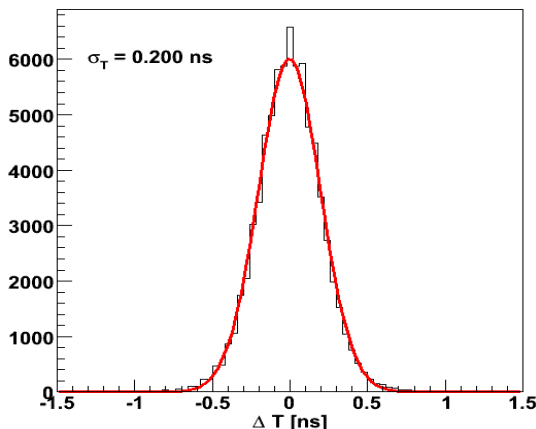

Figure 3: Timing resolution of a single S11 paddle for protons

Assuming negligible uncertainty in the projected position, a Gaussian fitted to this distribution yields a single standard deviation of  $\sigma \approx 200$  ps. Analysis of the performance of the TOF system is at a preliminary stage at the time of submission. For example, small deviations from linearity are visible in Fig. 2. The final analysis will take these non-linearities into account, and also the amplitude-dependent timing walk from leading-edge discrimination. At the current stage the S1 and S3 paddles show a resolution of about 200 ps, and about 150 ps for the S2 paddles.

Particles with higher charges produce more photons in the scintillator as for a proton of equal MeV/nucleon. Since the timing resolution should be proportional to the inverse square root of the number of photoelectrons (to the point where the electronic contribution becomes important), as an example the resolution for helium should be almost half the resolution for protons.

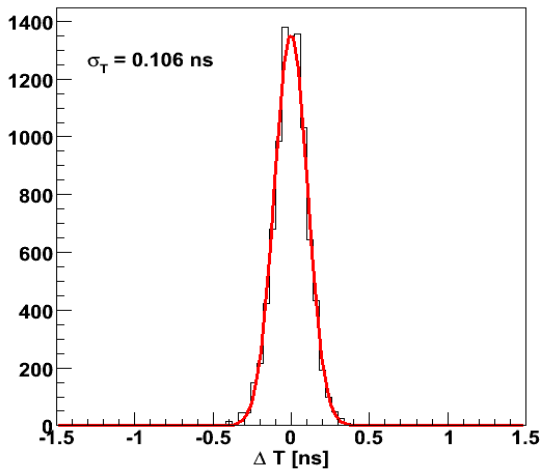

Figure 4: Timing resolution of a single S11 paddle for helium

In the preliminary analysis the flight data for  $Z=2$  has  $\sigma \approx 105$  ps, confirming this assumption, while for higher charges such as carbon we found only an improvement to  $\sigma \approx 85$  ps. This probably indicates that further effects limits the improvement, such as the non-linearities depicted in Figure 2 and the timing-walk. A previous test run at the GSI facility in Darmstadt, Germany, in February 2006, supports this assumption. In the beam test only a restricted portion of the scintillator was

illuminated with particles, and we reached a resolution in S1 and S3 paddles of  $\approx 45$  ps for carbon nuclei [4].

The TOF scintillators were assembled from fall 2002 to fall 2003, and each counter was tested with cosmic ray muons in the laboratory after the assembly. Compared to these results, the resolution for the scintillators obtained after the integration into the instrument in the second half of 2004 was about 30% worse for the paddles of S1 and S3 and less than 10% worse for the paddles of S2 [4]. This degradation in optical performance is not completely clear to us, but most probably it is due to a crazing of the surface of the scintillators which we found on spare scintillators of the original order. However, we do not see any further degradation of the scintillators in flight since launch.

### ToF Resolution

The actual  $\beta$  for a particle is derived from two paddles, which should degrade the resolution by a factor of  $\approx \sqrt{2}$ .

In Figure 5 we show the measured value of  $1/\beta$  for one paddle combination from the upper layer of S1 and the upper layer of S3 for relativistic protons by selecting events with  $R > 12$  GV/c.

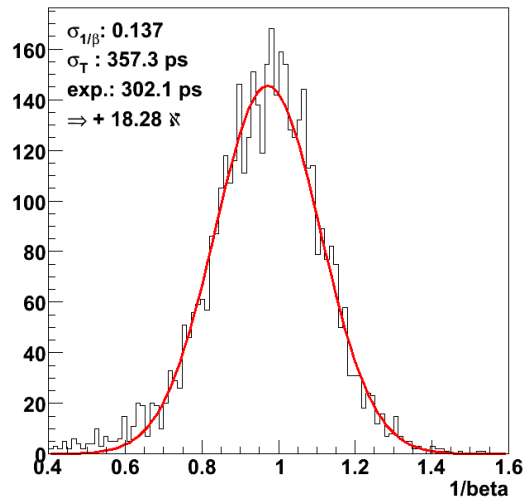

Figure 5: ToF resolution of one S11-S31 combination for protons

From the width of this distribution one can calculate the actual timing resolution for the full ToF

using two paddles: Since  $\beta = s/(c \cdot t)$ , with  $s$  the distance of the ToF layers and  $t$  the flight time, this results in:  $\Delta(1/\beta) = \Delta t \cdot c/s$ . In the combination shown above the actual resolution is about 20% worse than one would expect from the resolution of the single paddles. Since the system has more than just two layers, additional measurements for the same event are available, yielding an improvement of the timing resolution.

In Figure 6 we show the performance of separating particles mass for  $Z=1$  particles. This plot combines the rigidity measurement for the magnetic spectrometer and the beta from the ToF. In this case the beta was determined from four independent measurements using different layers of S1, S2, and S3. The solid lines in the plot show the expected behaviour for protons and deuterium. This figure illustrates the separation of the isotopes and also the identification of particles smaller than the proton mass.

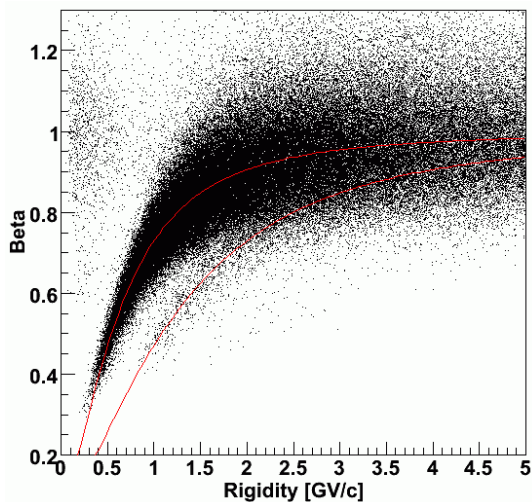

Figure 6: Beta versus rigidity plot for  $Z=1$  particles. The solid lines show the expected behaviour for protons and deuterium

### Charge Separation

The energy deposit of the particle in any of the ToF layers will vary as a function of both  $\beta$  and the charge of the particle. Careful measurement of the charge-integral of the PMT-pulses, corrected for incident position, together with the determina-

tion of  $\beta$  will therefore yield a measure for  $|Z|$ . As an example, Figure 7 shows a plot of the energy deposit measured by one of the photomultipliers in a S2 scintillator (in mip) versus  $\beta$  for flight data. The measured particles clearly fall into distinct, easily identified charge bands. Most of the particles in this figure are protons and helium, for the higher charges and a detailed description of the charge analysis using the ToF scintillators see another paper of this conference [6].

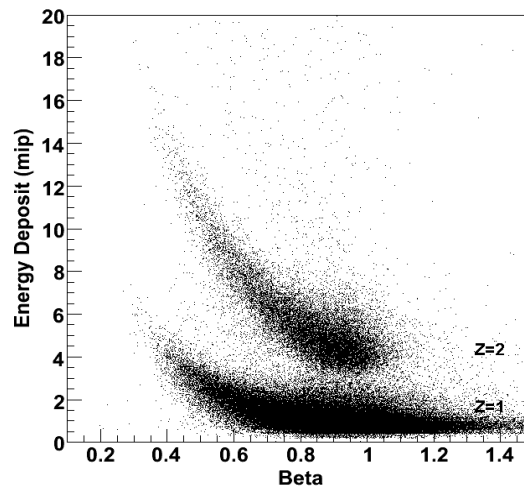

Figure 7: Charge bands for flight data measured by one photomultiplier in a S2 scintillator

### References

- [1] Picozza, P., et al., *Astroparticle Physics* 27 (2007) 296–315
- [2] Picozza, P. et al., “The Physics of Pamela Space Mission”, these proceedings, 2007
- [3] Boezio, M. et al., “The First Year in Orbit of the PAMELA experiment”, these proceedings, 2007.
- [4] G. Osteria, G. Barbarino, D. Campana, G. De Rosa, R. Rocco, S. Russo, W. Menn, M. Simon, J. Mitchell. 20<sup>th</sup> ECRS Lisbon, Portugal, 2006.
- [5] G. Osteria et al., *NIM A518* (2004), 161-163
- [6] Osteria, G. et al. “Light nuclei identification capability of the PAMELA apparatus”, these proceedings, 2007