



The Second Level Trigger of the PAMELA Space Experiment

S. ORSI¹ FOR THE PAMELA COLLABORATION

¹*The Royal Institute of Technology (KTH), Department of Physics, Albanova University Centre, SE-10691 Stockholm, Sweden*

silvio@particle.kth.se

Abstract: PAMELA is a satellite-borne experiment designed to study the charged component of the cosmic radiation of galactic, solar and trapped nature. The main scientific objective is the study of the antimatter component of cosmic rays over a wide range of energies. PAMELA is mounted on the Resurs DK1 satellite that was launched on June 15th 2006 and is orbiting the Earth on a semipolar (70°) elliptical ($350 \times 600 \text{ km}^2$) orbit. The experiment has a foreseen lifetime of at least 3 years. PAMELA is built around a permanent magnet silicon spectrometer, surrounded by a plastic scintillator anticoincidence shield. An electromagnetic calorimeter is used for particle identification and energy measurements. If PAMELA data exceed the storage allowance on the satellite or the daily downlink quota (now $\sim 20 \text{ GB}$), a second level trigger may be activated by uplink from ground. Information from the anticoincidence system and from the calorimeter will be included in the second level trigger condition, providing a selective reduction of data. The data reduction and the systematic uncertainties in the proton and electron spectra are evaluated with in-orbit data and compared to simulations.

Introduction

The PAMELA apparatus [1] was launched into space in a semipolar (70°) elliptical ($350 \times 600 \text{ km}$) orbit on the 15th June 2006 by a Soyuz-U rocket from the Baikonur cosmodrome in Kazakhstan. After a short commissioning phase, PAMELA has been acquiring data almost continuously since July 11th 2006 inside a pressurised container attached to the Russian Resurs-DK1 Earth-observation satellite. The PAMELA mission is devoted to the investigation of dark matter, the baryon asymmetry in the Universe, cosmic ray generation and propagation in our galaxy and the solar system, and to the study of solar modulation and interaction of cosmic rays with the Earth's magnetosphere [2]. PAMELA is built around a permanent magnet spectrometer with a variety of specialized detectors [3]. In particular below the tracker is placed the calorimeter, made of 44 highly segmented silicon sensor planes interleaved with 22 plates of tungsten absorbers (total depth $16.3 X_0$, i.e. 0.6λ), for a total of 4224 electronics channels (Si strips). The experiment is surrounded by a set of 9 anticoincidence (AC) detectors [4] which is used for

off-line rejection of particles not cleanly entering the PAMELA acceptance. The main trigger condition is given by coincidental energy deposits in the time-of-flight (ToF) scintillators. Information from the imaging electromagnetic calorimeter [6] and from the AC system are implemented in a second level trigger [7] to reduce online the data flow to be sent to ground, that may be activated by an uplink command from ground.

Data acquisition

Data acquisition from the subdetectors to the PAMELA on-board computer (PSCU) is performed via the Intermediate Data Acquisition System (IDAQ), at a rate of 2 MByte/s. When a particle enters the acceptance of the experiment and deposits coincidental energy in the ToF scintillators, the trigger front-end (FE) sends a trigger to the IDAQ. The PSCU, via the IDAQ, activates the procedure to sequentially read out the data from the subdetectors and to store them in the PSCU mass memory. Then, a few times a day, data are transferred into the satellite onboard memory, and

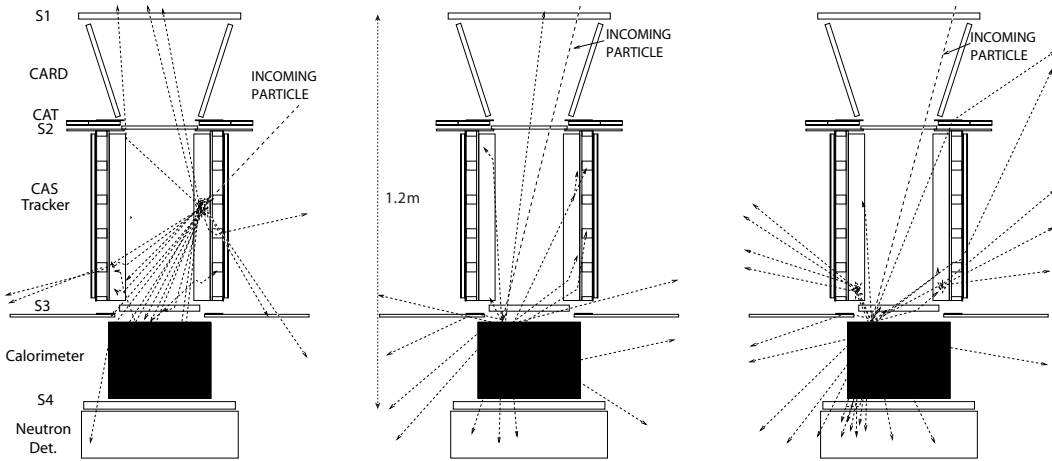

Figure 2: Visual representation of simulated proton interaction in the experiment. A particle entering the tracker cavity from the sides (false trigger, left) is often characterized by activity in the AC detectors, as are good trigger events with backscattering from the calorimeter (center). Right: Good trigger event without activity in the AC detectors.

stored before being down-linked to Earth. Few times a day the satellite transmits data to the down-link station at NTsOMZ in Moscow, and is currently sending to ground a total of 14-16 GB/day (it was 20 GB during the commissioning phase). The data acquisition system is dimensioned to handle the expected maximum data volume generated by PAMELA and The amount of daily downlinked data is enough to transmit to ground the data generated by PAMELA in normal conditions (average trigger rate ~ 20 Hz, average event size ~ 6 kB). Up to now there has therefore been no need to activate the second level trigger.

The tracker data compression algorithm has a compression factor of $\sim 95\%$, while a pedestal suppression method reduces the calorimeter data by 80% (a calibration is performed at each orbit; if a calibration fails, the calorimeter event is transmitted without data reduction). In the case any of the 2 compressions would fail, the event size would increase by a large factor, and so would the daily amount of data. If in the future the amount of data will exceed either the storage allowance dedicated to PAMELA on the Resurs spacecraft or the daily limit of data downlinked to ground, an online event selection can be applied through a second level (L2) trigger, to be activated by an uplink command

from ground. It should be noted that the L2 trigger is not implemented for any technical limitation of the experiment, that can continuously acquire data up to a trigger rate higher than ~ 60 Hz, generating more data than the mentioned quota of 20 GB. Apart from the South Atlantic Anomaly (SAA), where the data acquisition rate is fully governed by the dead time of the experiment, the expected trigger rate is always lower than the maximum trigger rate PAMELA is designed to manage.

The Second Level Trigger

The ongoing analysis of in-flight data confirms a result obtained with simulations, i.e. that the majority ($\sim 70\%$) of triggers in space are ‘false triggers’, i.e. where the coincidental energy deposits in the trigger scintillators are generated by secondary particles, produced in the mechanical structure of the satellite or of the experiment. The aim of the L2 trigger is to discard as many false triggers as possible, at the expense of losing a minor fraction of the good trigger events (i.e. the clean passage of a particle through the acceptance of PAMELA). The expected simulated differential proton trigger rate for PAMELA for good triggers (t_g), false triggers (t_f) and total ($t_t = t_g + t_f$) are shown in figure 1.

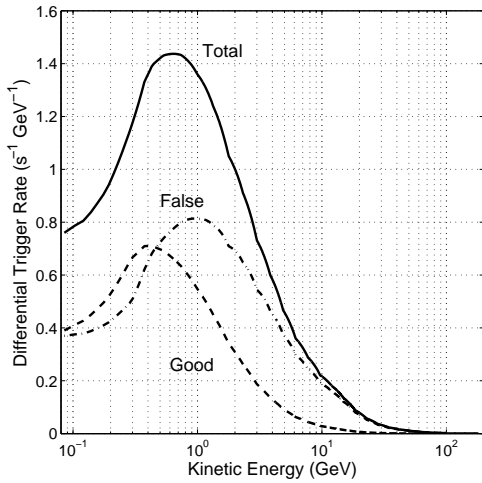

Figure 1: The simulated expected differential trigger rate shown as a function of the kinetic energy of the incoming proton for good triggers (dashed line), false triggers (dash-dot) and total (good+false, solid line). The plot contains simulated cosmic protons, averaged over one orbit.

Figure 2 shows a visual representation of simulated cosmic ray proton interactions in the experiment: a false trigger (left) and a good trigger without and with activity in the anticoincidence (AC) system (center and right, respectively). Most of the good triggers with AC activity are characterized by backscattering of particles from the calorimeter into one or more AC detectors. The second level trigger condition is based on information from the AC system and from the calorimeter: all the events characterized by activity in the AC system and with less than 70 silicon strips hit in the calorimeter are considered as false triggers and discarded.

The second level trigger algorithm has been implemented on a DSP (Digital Signal Processor) within the IDAQ and may be activated by the PSCU upon uplink commands from ground. When the second level trigger is activated, data are read out from the subdetectors to the IDAQ according to the selected trigger condition. The software running on the DSP checks the event by reading the words dedicated to the second level trigger in the AC and calorimeter sub-packets. If the event is recognized as false trigger, only a brief summary of the event is saved. The system is then ready for a new ac-

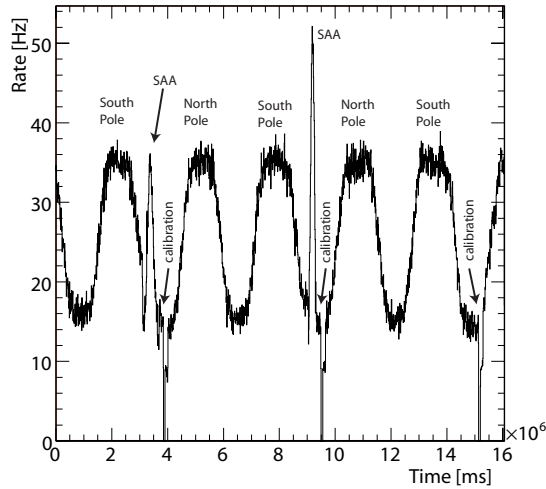

Figure 3: PAMELA trigger rate along 3 consecutive orbits.

quisition. One event every 10 is recorded using the main trigger condition, to monitor off-line the performance and efficiency of the second level trigger. This will allow a precise evaluation of the fraction of discarded good events, reducing the systematic errors significantly below the value of the inefficiencies discussed in the next section.

Tests with Cosmic Particles

Simulations performed before launch have shown that: 1. more than 70% of the false triggers are removed by the L2 condition (total data reduction $\sim 60\%$); 2. only 7% of the total good trigger events are discarded, with modification of the proton spectrum (inefficiency) lower than 10% over the energy range of interest; 3. for electrons the inefficiency is always less than 3% and decreasing with energy. An offline analysis making use of the L2 trigger condition applied on a subset of the in-flight data acquired with the main trigger condition has been performed. The results depend strongly on the event selection used for the analysis. A more strict selection (e.g. by requiring a better reconstructed track in the tracker) results in lower activity in the AC detectors, therefore in a lower rejection of good trigger events by applying the L2 trigger condition. Figure 4 shows the proton inef-

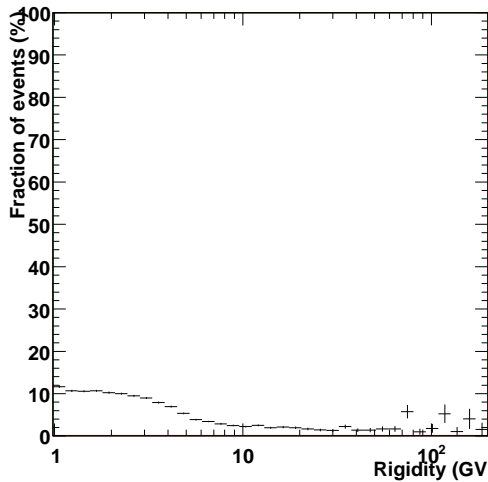

Figure 4: Inefficiency of the L2 trigger condition (fraction of good events rejected) on the proton spectrum as function of the proton rigidity for the 'strict event selection condition'.

efficiency as function of the incoming particle momentum, where the inefficiency is defined as the fraction of good triggers rejected by the L2 trigger condition. The total inefficiency for protons is $\sim 13\%$ for the loose selection and $\sim 18\%$ for the strict selection, while the total rejection ratio (fraction of false triggers rejected) is $\sim 60\%$.

The analysis of PAMELA in-flight data is in ongoing and the results concerning the second level trigger will be inserted in the final version of this article.

Conclusions

The data acquisition system is dimensioned to handle the expected maximum data volume generated by PAMELA and up to now there has been no need to reduce the PAMELA data flow. If in the future the amount of data will exceed either the storage allowance dedicated to PAMELA on the Resurs spacecraft or the daily limit of data downlinked to ground, an online event selection can be applied through a second level trigger, to be activated by an uplink command from ground. Tests performed

with cosmic particles show that the second level trigger is able to reject the majority of the false trigger events at the expense of losing a small fraction of good triggers.

References

- [1] P. Picozza et al., *Astrop. Phys.* **27** (2007) 296
- [2] P. Picozza et al., *The Physics of PAMELA Space Mission*, these proceedings
- [3] M. Boezio et al., *The First Year in Orbit of the PAMELA experiment*, these proceedings
- [4] S. Orsi et al., *Adv. in Space Research* **37** 10 (2006) 1853
- [5] S. Orsi et al., *A Study of the In-Orbit Particle Rate with the PAMELA Anticoincidence System*, these proceedings
- [6] M. Boezio et al., *Nucl. Instr. and Meth. in Phys. Res. A* **487** (2002) 407
- [7] S. Orsi et al., *Astroparticle Physics* **25** (2006) 33