

**WiZard 2: a Proposal to Complement WiZard Detector
with Two Further Modules of Tracking Calorimeter
and an Accurate Spark Counter t.o.f. System.**

P. SPILLANTINI, M. BOCCIOLINI, F. CELLETTI, M. MESCHINI and Y. F. WANG
INFN - Sezione di Firenze

G. BASINI, E. BONAVIRI, F. BONGIORNO, A. MORSELLI, M. OCCHIGROSSI
and M. RICCI
INFN, Laboratori Nazionali di Frascati - Frascati (Roma)

R. BERNABEI, V. BIDOLI, M. P. DE PASCALE and P. PICOZZA
Dipartimento di Fisica dell'Università di Roma II - Tor Vergata (Roma)

A. CODINO and M. MENICHELLI
Dipartimento di Fisica dell'Università - Perugia
INFN - Sezione di Perugia

C. DE MARZO
Dipartimento di Fisica dell'Università - Bari
INFN - Sezione di Bari

G. BARBIELLINI
Dipartimento di Fisica dell'Università - Trieste
CERN - Geneve

P. GALEOTTI
Laboratorio di Cosmogeofisica del CNR - Torino

(ricevuto il 4 Aprile 1989)

Summary. — Among the several existent proposals for the cosmic antimatter search, the WiZard project for the U.S. Space Station Freedom shows the greatest interest. A possible upgrading of the WiZard apparatus,

called WiZard 2, is presented in order to sensibly improve the capability of detecting antihelium nuclei in the cosmic radiation.

PACS 07.90 – Other topics in specialized instrumentation.

PACS 94.80 – Aerospace facilities and techniques; space research.

1. – Introduction.

One of the primary objectives of the WiZard experiment⁽¹⁾ proposed for the ASTROMAG facility is the search for antimatter. While antiprotons and positrons are produced as secondaries, possible antinuclei can have only a primary origin and the unambiguous detection of only one of them would be a discovery of fundamental significance.

The WiZard experiment aims at a sensitivity of one part in 10^8 in antihelium detection and a few parts in 10^7 for the other antinuclei in a three-year collection time. At the end of this period a possible scenario sees few antihelium candidates collected in the experiment. A probability of existence of antimatter could be given, but the unambiguous detection of one key-event founding its discovery could be missed. In fact, the antihelium identification must fight against a 10^{-8} error in charge sign assignment in helium detection and a 10^{-6} error in Z determination in \bar{p} detection. To rely for each kind of background on such a rejection based on one measured parameter only presents the usual difficulties related to unsuspected malfunctioning of the implied detector and to the difficult (and impossible to be tested) interpretation of the detector answer for extremely rare cases.

2. – Recall of the WiZard project.

The WiZard 2 design is devoted to a future upgrading of the WiZard apparatus when the requirement of a smaller weight will be hopefully no longer prohibitive and when the first phase will have reached its goals. The WiZard 2 concept is in fact intrinsically unified with WiZard and it is mainly because of the transport system necessity that a two-phase approach is safer. Therefore, let us briefly recall the main characteristics of the WiZard project (presented to the NASA scientific committees) which is a large collaboration between several U.S. and European institutions led by professor R. L. Golden as Principal Investigator.

⁽¹⁾ WiZARD: *A proposal to measure the cosmic rays, including antiprotons, positrons, nuclei, and to conduct a search for primordial antimatter*, submitted to NASA (November 1988).

The WiZard apparatus is basically composed of a transition detector (TRD), a time of flight (t.o.f.), a silicon calorimeter and a tracking chamber system; the apparatus is designed to work in the field of the magnet ASTROMAG (fig. 1).

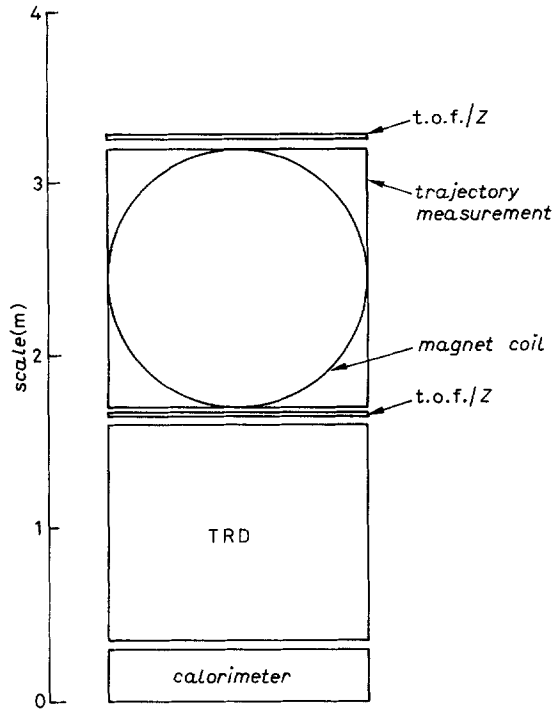

Fig. 1. - Scheme of the WiZard apparatus for the ASTROMAG facility.

The apparatus should be able to detect electrons and positrons, high-energy gammas, antiprotons and antialphas in cosmic rays in a range of few GeV up to hundreds GeV.

The systematic search for cosmic antimatter and the check of the various cosmological theories and models (from the leaky box model to the dark matter hypothesis involving photinos up to the idea of a matter-antimatter completely symmetric universe) are the main goals of this project and, of course, the antihelium detection plays a key role in such a research.

3. - Role of the tracking calorimeter in antihelium identification.

For this hypothetical key-event the possibility to «see it» directly through its unique annihilation pattern, that cannot be simulated neither by helium or other

nuclei interactions nor by antiprotons, constitutes an attractive possibility of «personal» signature of the event.

The antihelium nuclei will undergo the same geomagnetic cut-off as helium nuclei. Assuming the same energy spectrum, as for helium, their detection probability at the space station orbit (fig. 2) does not match the small depth of

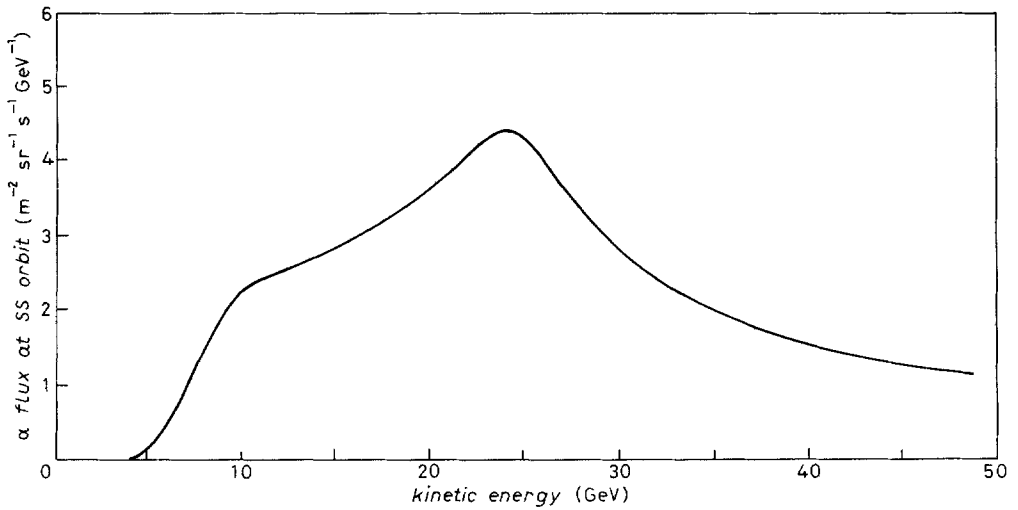

Fig. 2. - Detection probability of helium nuclei at the SS orbit.

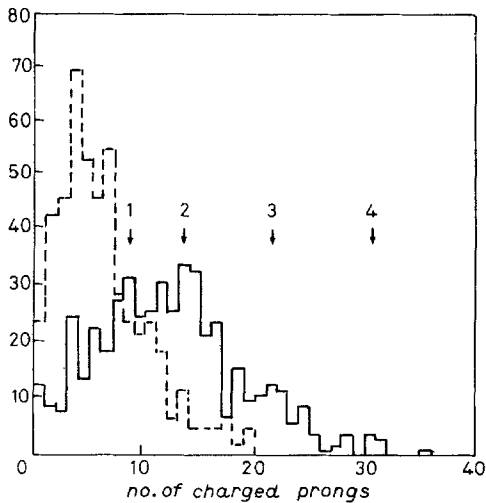

Fig. 3. - Distribution of the number of charged prongs produced by antihelium (solid line) in the WiZard calorimeter (*i.e.* in the first module of the «full containment» calorimeter) compared with that for helium (broken line) at the same total energy (20 GeV). The arrows indicate the multiplicity regions of the number of annihilation vertices.

the WiZard calorimeter (0.5 interaction lengths) because at the implied energies none of the possible antihelium nuclei could be conducted at rest to annihilate inside the calorimeter.

However, the four antinucleons composing the antihelium could annihilate in flight, possibly after undergoing the scatterings of the respective nucleons. To evaluate them we used the GEANT-3 program widely used to simulate particle interaction in matter for high-energy elementary-particle experiments. At the involved energies the independent-spectator model can be used to simulate the antihelium interaction as the addition of the interaction of two antiprotons and two antineutrons with the calorimeter material. The same procedure was used to obtain helium nuclei interactions adding up two protons and two neutrons.

In fig. 3 the distribution of the number of charged prongs produced by antihelium in the calorimeter is compared with that for helium at the same energy (20 GeV). The fully annihilated antihelium events contribute to the tail of the distribution. They can be well identified already on the basis of this rough integral parameter, but are very few (3% of the total).

4. – The «full containment» tracking calorimeter.

To increase the fraction of antihelium nuclei undergoing full annihilation it is necessary to substantially increase the depth of the calorimeter.

We propose to consider the calorimeter proposed in the WiZard experiment as the first module of a bigger tracking calorimeter, in which this first module will be complemented by other two modules, identical in detection technique and possibly in external dimensions and connections, and of the same weight about.

The first module («electromagnetic» module) has a tungsten absorber to optimize in the WiZard experiment the rejection of proton background in positron detection. The second («vertex» module) could have a copper absorber and will contain most of the annihilation and scattering vertices, and the third one («containment» module) could be still in copper and will be devoted to confine a large fraction of annihilation prongs. A sketch of this three modules and their possible layer structure are given in fig. 4.

A large fraction of antihelium nuclei (from 1/3 to more than 2/3 in the foreseen collection energy range) will undergo full annihilation in this calorimeter. As done above for the first module we compare in fig. 5 and 6 the distributions of the number of charged prongs produced by antihelium in the whole calorimeter with those for helium at the same energies. They show a clear signature already on the basis of this integral parameter of about 50% to 20% of the antihelium events in the whole effective collection energy range.

For a sufficient granularity of the tracking capability of the calorimeter the full antihelium identification will also rely on the angular and energy distributions of these prongs, as well as on their distribution among the

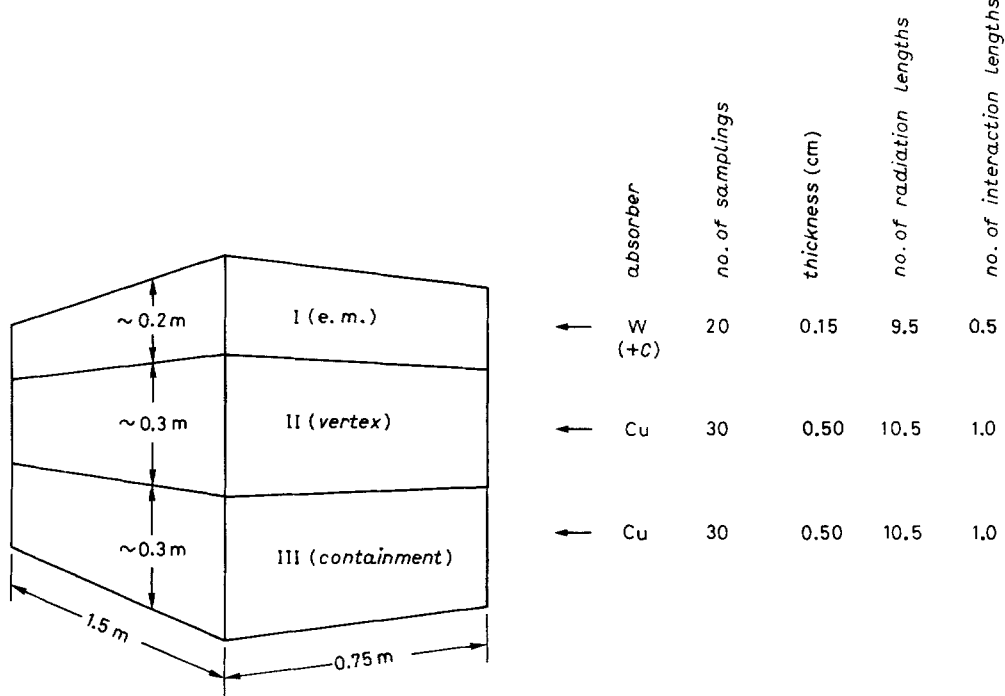

Fig. 4. - Sketch of the three modules of the «full containment» calorimeter.

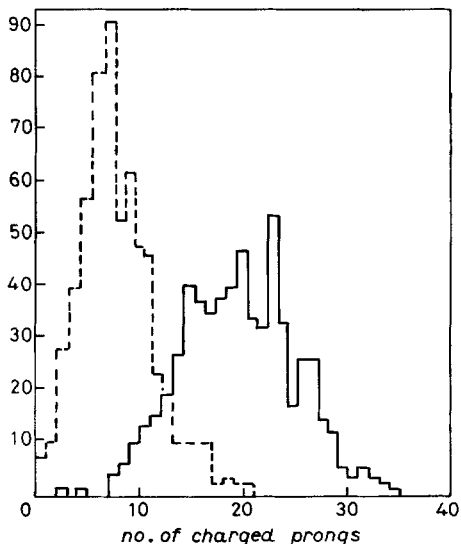

Fig. 5.

Fig. 5. - Distribution of the number of charged prongs produced by antihelium (solid line) in the «full containment» calorimeter compared with that for helium (broken line) at the same total energy (14 GeV).

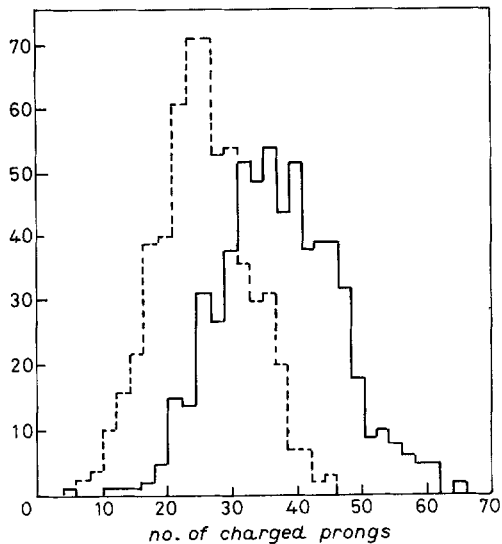

Fig. 6.

Fig. 6. - Distribution of the number of charged prongs produced by antihelium (solid line) in the «full containment» calorimeter compared with that for helium (broken line) at 28 GeV.

scattering and annihilation vertices. It is important to remark that the identification of only one annihilation vertex will be sufficient to establish the «antimatter nature» of the incoming particle.

An example of typical antihelium event tracked in the calorimeter is reproduced in fig. 7. In this event one \bar{p} annihilates already in the electromagnetic module without undergoing any scattering, the second \bar{p} interacts in the vertex module and leaves the calorimeter without further interactions, one \bar{n} interacts and annihilates in the vertex module and the other \bar{n} annihilates in the electromagnetic one.

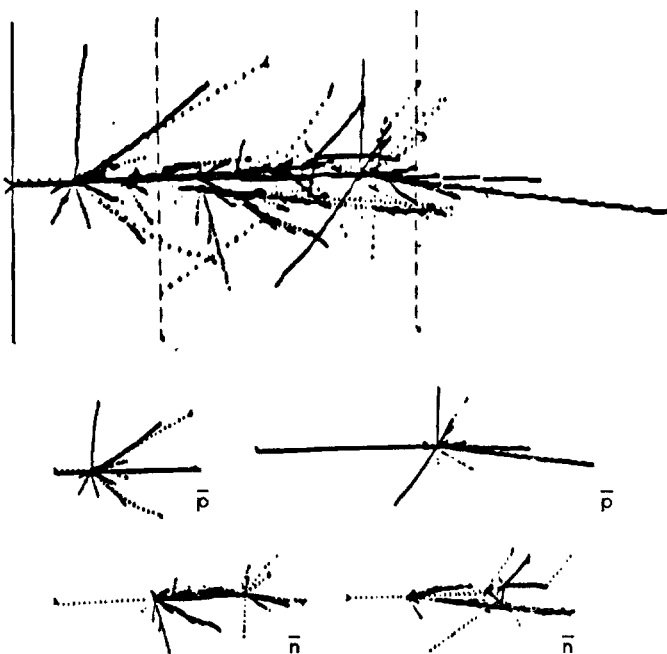

Fig. 7. - Typical antihelium event tracked in the «full containment» calorimeter.

The granularity foreseen for the electromagnetic module (sampling each 1/3 of radiation length with a 4 mm granularity in both the two orthogonal views) if extended to the vertex and containment modules is sufficient to do full use of the rich information contained in the pattern. The event in fig. 6 was drawn just with this granularity. Such a granularity implies the use of $1.5 \cdot 10^4$ readout channels and 30 m^2 of silicon detector for each module. A suitable optimization could reduce, perhaps substantially, these figures. However, the three modules should be as similar as possible and use the same electronics, same controls and same data acquisition, reduction and transmission, in order to cut the cost of their spatialization (namely part of the project, the models and the qualification tests) to the cost of the spatialization of only one of them.

The addition of the vertex and containment modules to the WiZard apparatus is compatible with the power and data communication resources foreseen at the attachment place, provided that the attachment points will be foreseen in the suitable positions. Also the mechanical compatibility with the WiZard apparatus can be easily assured either because the material introduced by a possible vessel enclosing the electromagnetic module is negligible inside the calorimeter, or because the calorimeter makes use of silicon detectors and does not require any vessel.

Although if dimensioned for antihelium identification the complete calorimeter will play an important role in other items:

i) Electromagnetic showers initiated by electrons, positrons and gammas will be fully contained till the highest energies detectable in the WiZard experiment. Their identification and the measurement of their energy will be significantly improved.

ii) More than 90% of antiprotons will annihilate in this calorimeter and more than half of them will have the annihilation products fully contained inside, allowing the comparison of the total released energy with the momentum measured in the magnetic spectrometer. The quality of antiproton identification will result substantially improved.

iii) The high fraction of helium nuclei whose shower is fully contained in the calorimeter (from 5% to 10% in the collection energy range) allows the separation of helium-3 and helium-4 isotopes on statistical basis, and event by event in a sub-sample, on the basis of the released energy and pattern parameters (prongs, vertices,..).

5. - High resolution t.o.f. system.

Concerning this last point it must be noted that a clear separation of the two isotopes in the maximum collection energy range (*i.e.* up to $(25 \div 30)$ GeV) is possible if a resolution of $(20 \div 25)$ ps can be achieved for the t.o.f. resolution on a three-meter long basis.

This separation is of some importance also in the case of the detection of an antihelium key-event because it was argued^(*) that antihelium-3 nuclei could be produced by collision on interstellar matter with a not completely negligible probability; such speculations could spoil the fundamental significance of the discovery and can be overcome only by the identification of the isotopic nature of the annihilation antihelium event.

(*) YU. N. PESTOV: *Proceedings of the III International Conference on Instrumentation for Colliding Beam Physics* (Novosibirsk, 1984), p. 163.

For a fraction of the antihelium-4 events (from 55% to 29% in the $(12 \div 24)$ GeV/c range) all the four annihilation vertices will be contained in the calorimeter volume and could allow the isotopic number identification at some degree of confidence. If we consider that the possible sample of antihelium candidates could be very poor and the fraction of the antihelium-3 isotope very high (it is 1/4 for the helium), the calorimetric identification is very poor for such an identification.

It is indeed worthwhile seeking for a t.o.f. system which could reach the $(20 \div 25)$ ps resolution mentioned above. The only technique used until now in elementary-particle experiments able to give such a resolution on sizable surfaces ($0.2 \times (1 \div 2)$ m² elements) is that of small gap spark counters: a limited-current spark develops in the $(50 \div 100)$ μ m gap between two plane surfaces in the point where the going-through particle ionized the gas filling the gap.

Small-gap spark counters were constructed and operated in Novosibirsk⁽²⁾, Berkeley⁽³⁾ and KEK⁽⁴⁾ laboratories to provide an accurate localization of elementary particles. Because of their unitary charge a large amount of gas must occupy the gap in order to reach a high efficiency. This means that these counters had to be operated at high pressure (of the order of 10 atm). A relatively heavy pressure vessel must indeed surround the counter, preventing its use for nuclei. Furthermore the two planes must be very stiff to support the pressure of the electrostatic field; the adopted solution was that of depositing a metallic layer on thick (2 or more mm) glass plates. Also because of the necessary presence of the pressure container no special technical research for light stiff structures was conducted.

When used for nuclei these counters can profit of the Z^2 -dependence of the ionization power. The corresponding pressure for an efficient helium detection could be indeed reduced to about 3 atm. A further decrease of pressure for a 1.5 factor could be obtained by substituting xenon to argon in the gas mixture and accepting a loss in detection efficiency: for helium nuclei we could obtain an efficiency of 60% and 84% for 50 and 100 μ m gap operating the spark counters at 1 atm.

We will try to operate these counters in these conditions and will conduct the necessary technical research to produce stiff plates suitably light.

The development of a t.o.f. technique able to reach the tens ps resolution is very important for isotope identification in space experiments. When used in conjunction with the good Z resolution of the Wizard experiment it allows an isotopic separation on an energy range going till 5.5 (16) GeV/nucl for helium to 4 (5) GeV/nucl for beryllium and boron assuming a 20 ps resolution on 3 m basis and a 2.36 (1.0) standard deviation separation for the two contiguous isotopes.

⁽³⁾ A. OGAWA, W. B. ATWOOD, N. FUJIWARA, YU. N. PESTOV and R. SUGAHARA: *IEEE Trans. Nucl. Sci.*, NS-31, 121 (1984).

⁽⁴⁾ N. FUJIWARA, N. IIDA, S. NOGUCHI, R. SUGABARA, T. SUWADA, T. OHAMA and K. TAKAHASHI: *Nucl. Instrum. Methods. A*, 263, 381 (1988).

● RIASSUNTO

Fra tutte le varie proposte esistenti nell'ambito della ricerca di antimateria cosmica, il progetto WiZard per la Stazione Spaziale americana Freedom si dimostra del piú grande interesse. Si presenta un possibile ampliamento dell'apparato WiZard allo scopo di migliorare sensibilmente la capacità di rivelare nuclei di antielio nella radiazione cosmica.

Резюме не получено.